

# Maritime New Zealand Guidelines

## SAFETY BULLETIN ISSUE 10 2007

May 2007

### LIFERAFTS AND THEIR RELEASE MECHANISMS

This Safety Bulletin is for:

- safe ship management companies
- ship surveyors
- Maritime Safety Inspectors
- owners and operators
- skippers and crew
- liferaft servicing stations.

### Will your liferaft save your life?

It is blowing 40 knots, raining, night-time; your vessel is sinking and you have to abandon ship. Your best chance of survival in the freezing sea is a liferaft.

If your vessel capsizes, can the liferaft escape? Make sure the:

- Hydrostatic release unit (HRU) is connected correctly
- Liferaft is not prevented from escaping by extra lashings or rigging on the vessel, or by a cover on the liferaft

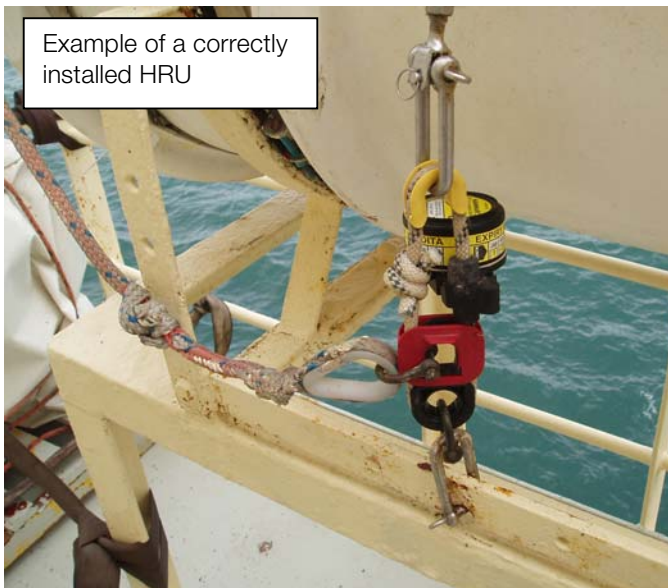

## Common problems with liferafts

Make sure the following happens on your vessel:

- the liferaft is **NOT** stowed in an area where rigging will prevent the liferaft being able to leave the vessel
- the liferaft is **NOT** stowed in a cradle that is too tight to release the liferaft in an emergency
- there is **NO** cover over the liferaft that may stop it from inflating
- gear is **NOT** stowed around the liferaft, making manual operation difficult and reducing the liferaft's ability to deploy
- easy access **IS** provided to the liferaft when it is stored in a difficult location, e.g. the wheelhouse roof.

## Manual release liferafts

The manual release on a liferaft is more likely to be used in an emergency than waiting for the hydrostatic release unit to deploy.

### Common problems

- Manual release is difficult to operate owing to lack of maintenance or seized parts.
- The liferaft is difficult to get over the side of the vessel because it is obstructed by guardrails or rigging.

## Float-free liferafts and the hydrostatic release unit (HRU)

Float-free launching is the method of launching a liferaft whereby it is automatically released from a sinking ship and is ready for use. Float-free arrangements may either be an HRU or some other means. Whatever type it is, if your vessel capsizes too quickly for you to release the liferaft manually the float-free arrangement may be your only chance of survival.

Please see the diagrams at the end of the safety bulletin on the correct installation of an HRU.

### Common problems

- The painter is connected to the ship and not the weak link, so the liferaft inflates but goes down with the ship.
- The disposable HRU is out-of-date and will not work.
- The serviceable HRU has not been serviced and will not work.
- The expiry date is not marked on the HRU when it is replaced so there is no record of when to replace it.

## Conclusion

In the event of capsizing and/or sinking the liferaft is your best chance of survival.

It is important that:

- every crewmember is trained in how to maintain and deploy the liferaft
- the liferaft is easy to get to for manual release
- the liferaft is stowed in an area clear of rigging and in a cradle that will allow the liferaft to escape
- on float-free liferafts the HRU has up-to-date service and expiry dates.

## Recommendations/actions

- During maintenance checks make sure your liferaft and its connections are in accordance with the advice in this safety bulletin.
- The procedure for connecting each of your liferafts and how to care for them should be in your SSM manual.

### Further Information

For further information, please contact:

Nautical Analyst, Maritime New Zealand

Phone: (04) 494 1209

Fax: (04) 494 1263

Email: [nautical.analyst@maritimenz.govt.nz](mailto:nautical.analyst@maritimenz.govt.nz)

# CORRECT INSTALLATION OF HYDROSTATIC RELEASE UNIT (HRU)

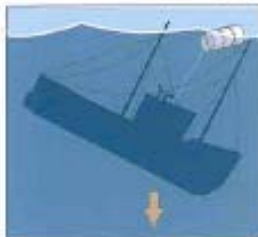
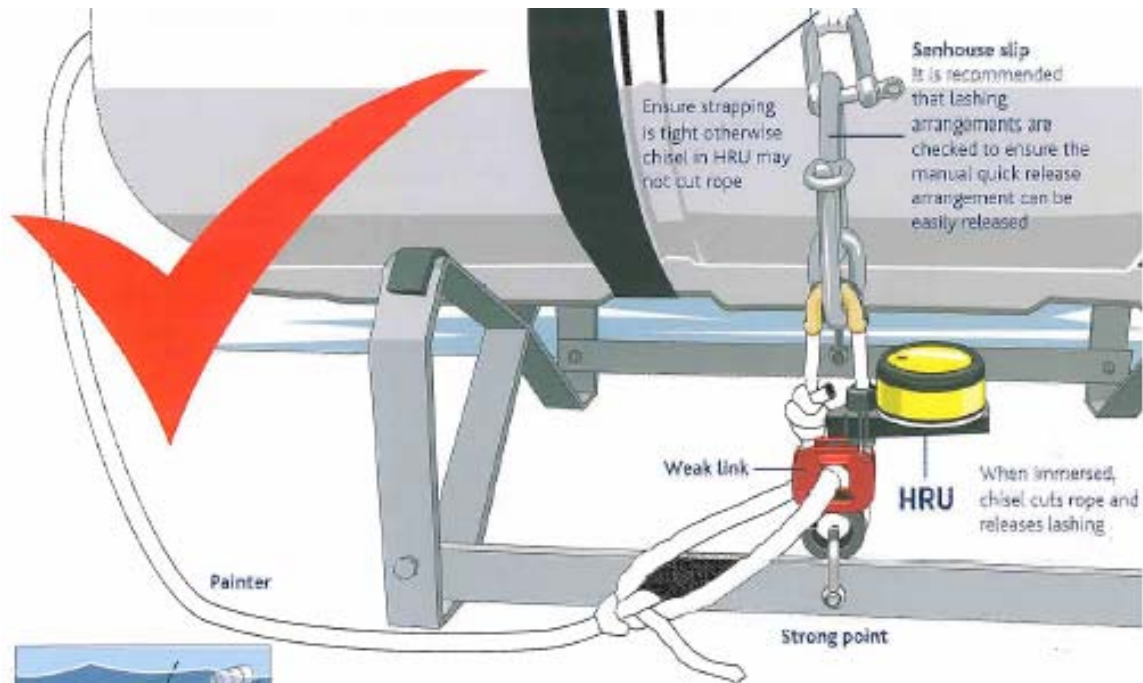

1. If vessel sinks, Hydrostatic Release Unit activates and liferaft attempts to float to surface



2. Tension on painter will cause liferaft to inflate

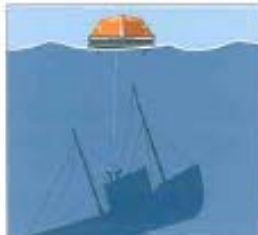

3. Tension on weak link will cause it to break ensuring liferaft does not go down with the boat

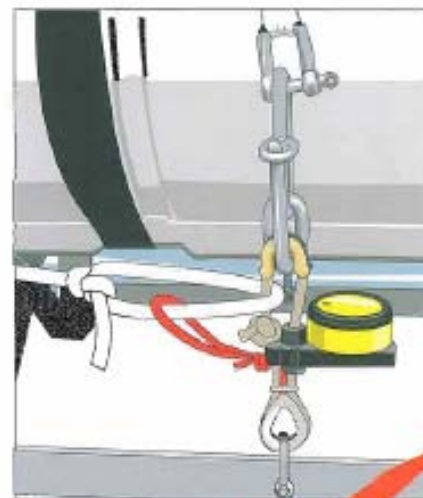

Correct installation of older version HRU



# INCORRECT INSTALLATION OF HRU

Painter secured to HRU  
(not through weak link)

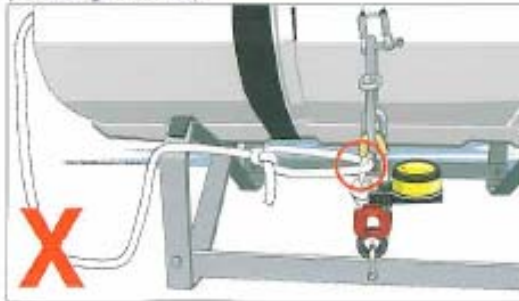

1. HRU will activate
2. Liferaft will be released but will **NOT** automatically inflate and will eventually drift away

Painter secured to senhouse slip

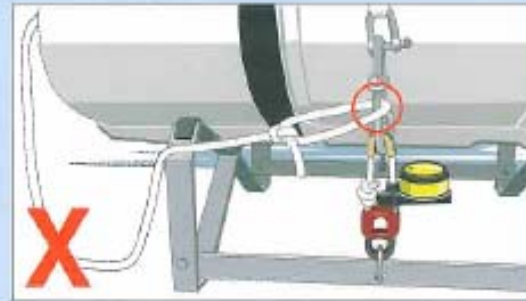

1. HRU will activate
2. Liferaft will float free and eventually inflate
3. Because the painter is secured to the slip, the liferaft will **NOT** be released to the surface

Painter secured directly to strong point

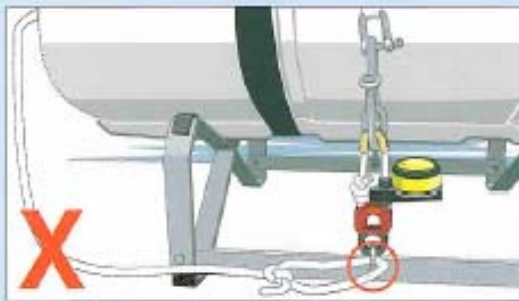

1. HRU will activate
2. Liferaft will float free and eventually inflate
3. Because the painter is secured directly to the strong point, the liferaft will **NOT** be released to the surface **EVEN IF** it is attached to the weak link as well

Painter secured only to weak link  
(older version only)

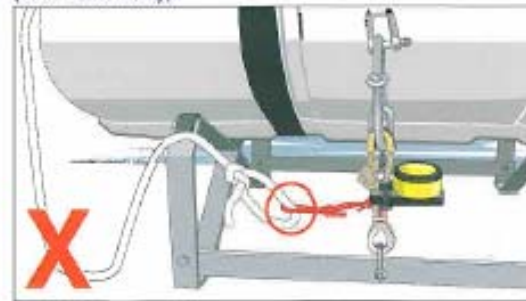

1. Will work correctly for automatic release, but:
2. If liferaft is thrown overboard in an emergency (or comes adrift at sea) it may be lost