

Maritime Rules

Part 48: Tonnage Measurement

Maritime New Zealand Consolidation

1 December 2025

ISBN 978-1-991352-08-8

Published by

Maritime New Zealand, PO Box 25620, Wellington 6140, New Zealand

Maritime New Zealand Copyright 2025

Part objective

Part 48 prescribes the tonnage measurement requirements for ships of 24 metres or more in length which are to be registered in Part A of the New Zealand Register of Ships. It also requires New Zealand commercial ships of 24 metres or more in length which are not required to be registered in Part A of the New Zealand Register to be measured for tonnage.

Each ship measured for tonnage is required to be issued with a tonnage certificate, the form of which is prescribed in the rules, and which is to be maintained on board.

Part 48 implements New Zealand's obligations under the International Convention on Tonnage Measurement of Ships, 1969. In this respect there is a requirement in the rules that the tonnage and certificate held by a foreign ship at a New Zealand port may be verified.

Part 48 also requires New Zealand Defence Force ships of 24 metres or more in length to be measured for tonnage.

The authority for making Part 48 is found in sections 36(r) and (u) of the Maritime Transport Act 1994.

Maritime Rules (rules) are secondary legislation under the Legislation Act 2019. Under that Act, the rules are required to be presented to the House of Representatives. The House may, by resolution, disallow any rule. The Regulations Review Committee is the select committee responsible for examining all secondary legislation and may consider any matter relating to secondary legislation and report on it to the House. Anyone can make a complaint to the Regulations Review Committee about the operation of secondary legislation.

Disclaimer:

This document is the current consolidated version of Maritime Rules Part 48 produced by Maritime New Zealand, and serves as a reference only. It has been compiled from the official rules that have been signed into law by the Minister of Transport. Copies of the official rule and amendments as signed by the Minister of Transport may be downloaded from the Maritime New Zealand website.

www.maritimenz.govt.nz

History of Part 48

Part 48 first came into force on 15 October 1998 and now incorporates the following amendments:

Amendment	Effective date
Amendment 1	27 May 2004
Amendment 2	4 September 2008
Amendment 3	30 July 2009
Amendment 4	1 April 2011
Amendment 5	1 July 2014
Amendment 6	1 April 2015
Amendment 7	13 December 2019
Amendment 8	31 March 2021
Amendment 9	1 December 2025

Summary of amendments

Amendment 1 Maritime Amendments Parts 20-90	PO, 48.2, 48.7
Amendment 2 Maritime (Various Amendments) Rules 2008 (Part 20-91)	48.2, 48.3(1)(a), 48.8
Amendment 3 Maritime (Various Amendments) Rules 2009, Parts 21-80	48.12(1), Appendix 2
Amendment 4 Maritime Rules Various Amendments 2011	48.12(1)
Amendment 5 Parts 19 and 44: Consequential Amendments	48.2
Amendment 6 Maritime Rules Various Amendments 2015	48.2
Amendment 7 Maritime Rules Various Amendments 2019	48.2
Amendment 8 Maritime Rules (International Omnibus) Various Amendments 2020	48.2
Amendment 9 Maritime Rules Amendments 2025 (No 2)	Part Objective, 48.2

All signed rules can be found on our website:
<https://www.maritimenz.govt.nz/rules/all-rules/>

Contents

General	1
48.1 Entry into force	1
48.2 Definitions.....	1
Ships of 24 metres length or more	5
48.3 Application.....	5
48.4 Requirement for ship to be measured for tonnage	5
48.5 Determination of tonnage.....	5
48.6 Gross tonnage.....	6
48.7 Net tonnage.....	6
48.8 Marking cargo spaces	6
48.9 Change of tonnage.....	7
48.10 Measurement and calculation	7
48.11 Oil tankers with segregated ballast tanks	7
48.12 Issue of certificates.....	8
48.13 Port State Control.....	8
Appendix 1 Figures referred to in the definition of "excluded spaces" in section 1	10

General

48.1 Entry into force

Part 48 shall come into force 28 days after its notification in the *Gazette*.

48.2 Definitions

In this Part—

Act means the Maritime Transport Act 1994:

authorised organisation means an organisation which has entered into a memorandum of agreement with the Director in compliance with the International Maritime Organization Assembly Resolution A.739(18) and the Annexes thereto entitled *Guidelines for the Authorisation of Organizations Acting on Behalf of the Administration*, whereby that organisation may undertake the measurement of New Zealand ships for the purpose of calculating the gross and net tonnages in accordance with the International Convention on Tonnage Measurement of Ships:

authorised person means a person employed by an authorised organisation who has delegated powers from the Director to issue and suspend or to issue or to suspend certain maritime documents under Part 5 of the Maritime Transport Act 1994, pursuant to an instrument of delegation made under section 444 of the Maritime Transport Act 1994:

breadth means the maximum breadth of the ship, measured amidships to the moulded line of the frame in a ship with a metal shell and to the outer surface of the hull in a ship with a shell of any other material:

cargo spaces means enclosed spaces appropriated for the transport of cargo which is to be discharged from the ship, provided that such spaces have been included in the calculation of gross tonnage:

Certificate of Surveyor Recognition—

- (a) has the same meaning as in Part 44; and
- (b) includes any document that is deemed under Part 44 to be a valid Certificate of Surveyor Recognition:

current, in relation to a document means that it is valid, has not expired, and, in the case of a maritime document, has not been suspended or revoked by the Director:

Director means the person who is for the time being the Director of Maritime Safety under section 439 of the Maritime Transport Act 1994:

enclosed spaces means all those spaces, except excluded spaces, which are bounded by the ship's hull, by fixed or portable partitions or bulkheads, by decks or coverings other than permanent or movable awnings. No break in a deck, nor any opening in the ship's hull, in a deck or in a covering of a space, or in the partitions or bulkheads of a space, nor the absence of a partition or bulkhead, precludes a space from being included in the enclosed space:

excluded spaces means the spaces described in the following paragraphs:

- (a) A space within an erection where the space is opposite an end opening that—
 - (i) extends from deck to deck except for a curtain plate of a depth not exceeding by more than 25 millimetres the depth of the adjoining deck beams; and
 - (ii) has a breadth equal to or greater than 90 percent of the breadth of the deck at the line of the end opening, and—

the space is between the actual end opening and a line drawn parallel to the line of the end opening at a distance from the end opening equal to one half of the width of the deck at the line of the end opening (see Figure 1 in Appendix 1):

- (b) A space within an erection where the space is—
 - (i) opposite an end opening; and
 - (ii) the width of the space, because of any arrangement except by convergence of the outside plating, becomes less than 90 percent of the breadth of the deck; and
 - (iii) between the line of the end opening and a line drawn parallel to the line of the end opening through the point where the athwartships width of the space becomes equal to 90 percent of the breadth of the deck (see Figures 2, 3 and 4 in Appendix 1):
- (c) A space within an erection which—
 - (i) has completely open sides except for bulwarks or open rails; and
 - (ii) separates any two spaces within the erection, one or both of which are excluded spaces under paragraphs (a) or (b), and—

the length of separation between the two spaces is not less than the least half breadth of the deck in way of the separation (see Figures 5 and 6 in Appendix 1):
- (d) A space under an overhead deck covering open to the sea and weather, if—
 - (i) the deck has no other connection on the exposed sides with the body of the ship than the stanchions necessary for its support; and
 - (ii) where open rails or a bulwark and curtain plate are fitted or stanchions are fitted at the ship's side, the distance between the top of the rails or the bulwark and the curtain plate is not less than 0.75 metres or one-third of the height of the space, whichever is the greater (see Figure 7 in Appendix 1):
- (e) A space in a side-to-side erection directly in way of opposite side openings if the height of the opening is not less than 0.75 metres or one-third of the height of the erection, whichever is the greater.

Where the opening is provided on one side only, the excluded space is limited inboard from the opening to a maximum of one-half of the breadth of the deck in way of the opening (see Figure 8 in Appendix 1):

- (f) A space in an erection immediately below an uncovered opening in the deck overhead, where the opening is exposed to the weather (see Figure 9 in Appendix 1):
- (g) A recess in the boundary bulkhead of an erection which is exposed to the weather where—
 - (i) the opening of the bulkhead extends from deck to deck without means of closing; and
 - (ii) the interior width of the recess is not greater than the width at the entrance and its extension into the erection is not greater than twice the width of its entrance (see Figure 10 in Appendix 1):

foreign ship means any ship that is not a New Zealand ship:

International Tonnage Certificate (1969) means—

- (a) in relation to a New Zealand ship, a maritime document issued under Part 5 of the Maritime Transport Act 1994 in accordance with rule 48.12; and
- (b) in relation to a foreign ship, the international tonnage certificate referred to in rule 48.12:

length means 96 percent of the total length on a waterline at 85 percent of the least moulded depth measured from the top of the keel, or the length from the fore side of the stem to the axis of the rudder stock on that waterline, if that be greater. In ships designed with a rake of keel the waterline on which this length is measured is to be parallel to the designed waterline:

moulded depth means the vertical distance measured from the top of the keel to the top of the upper deck beam at side; provided that—

- (a) in wood and composite ships the distance is measured from the lower edge of the keel rabbet; and
- (b) where the form of the lower part of the midship section is of hollow character, or where thick garboards are fitted, the distance is measured from the point where the line of the flat of the bottom continued inwards cuts the side of the keel; and
- (c) in ships having rounded gunwales, the distance is measured to the point of intersection of the moulded lines of the deck and sides, the lines extending as though the gunwale were of angular design; and
- (d) where the upper deck is stepped and the raised part of the deck extends over the point at which the moulded depth is to be determined, the distance is measured to a line of reference extending from the lower part of the deck along a line parallel with the raised part:

moulded draught means one of the following draughts:

- (a) for ships for which an International Load Line Certificate has been issued in accordance with Part 47, the draught corresponding to the assigned Summer Load Line (other than timber load lines); or
- (b) for passenger convention ships, the draught corresponding to the deepest assigned subdivision load line; or
- (c) for ships for which a New Zealand Load Line Certificate has been issued in accordance with Part 47, the draught corresponding to the assigned Summer Load Line; or
- (d) for other ships, 75 percent of the moulded depth amidships:

New Zealand commercial ship means a New Zealand ship that is not—

- (a) a pleasure craft; or
- (b) solely powered manually; or
- (c) solely powered by sail:

New Zealand Defence Force has the same meaning as the term "Defence Force" in section 2(1) of the Defence Act 1990:

New Zealand-owned ship has the same meaning as in the Ship Registration Act 1992:

New Zealand ship means a ship that is registered under the Ship Registration Act 1992; and includes a ship that is not registered under that Act but is required or entitled to be registered under that Act:

passenger means any person carried on a ship, other than:

- (a) the master and the members of crew, and any other person employed or engaged in any capacity on board the ship on the business of the ship; and
- (b) a person on board the ship either in pursuance of an obligation laid upon the master to carry shipwrecked, distressed, or other persons, or by reason of any

circumstance that neither the master nor the owner nor the charterer (if any) could have prevented or forestalled; and

- (c) a child under the age of 1 year:

passenger convention ship means a ship—

- (a) carrying more than 12 passengers and complying with the requirements of the International Convention for the Safety of Life at Sea 1974; and
- (b) having subdivision load lines assigned under that convention:

pleasure craft means a ship that is used exclusively for the owner's pleasure or as the owner's residence, and is not offered or used for hire or reward; but does not include—

- (a) a ship that is provided for transport or sport or recreation by or on behalf of any institution, hotel, motel, place of entertainment, or other establishment or business;
- (b) a ship that is used on any voyage for pleasure if it is normally used or intended to be normally used as a fishing ship or for the carriage of passengers or cargo for hire or reward;
- (c) a ship that is operated or provided by any club, incorporated society, trust, or business:

register length in relation to any ship, means the length of the ship measured from the foreside of the head of the stem to the aft side of the head of the stern post or, in the case of a ship not having a stern post, to the foreside of the rudder stock:

Provided that, in the case of a ship not having a stern post or rudder stock, the after terminal point shall be taken to be the aftermost part of the transom or stern of the ship:

segregated ballast oil tanker means any oil tanker which is certified as a segregated ballast oil tanker in paragraph 5 of the Supplement to the International Oil Pollution Prevention Certificate required by rule 123A.6(1)(b), and which has the segregated ballast tanks located as indicated in paragraph 5.2 of that Supplement:

surveyor means –

- (a) a person employed by an authorised organisation to undertake an activity that Part 48 requires be undertaken by a surveyor; or
- (b) a person who holds a current Certificate of Surveyor Recognition:

tonnage convention means—

- (a) the International Convention on Tonnage Measurement of Ships 1969; and
- (b) the Regulations annexed to that Convention and any amendments of those Regulations:

upper deck means the uppermost complete deck exposed to weather and sea—

- (a) which has permanent means of weathertight closing of all openings in the weather part thereof; and
- (b) below which all openings in the sides of the ship are fitted with permanent means of watertight closing.

In a ship having a stepped upper deck, the lower line of the exposed deck and the continuation of that line parallel to the upper part of the deck is taken as the upper deck:

volume of all enclosed spaces means, for the purposes of rule 48.6, the volume of enclosed spaces minus the volume of any excluded spaces unless that excluded space complies with at least one of the following 3 conditions—

- (a) the space is fitted with shelves or other means for securing cargo or stores; or
- (b) the openings are fitted with any means of closure; or
- (c) the construction provides any possibility of such openings being closed:

weathertight means that in any sea conditions water will not penetrate into the ship.

Ships of 24 metres length or more

48.3 Application

- (1) Rules 48.4 to 48.12 inclusive apply to—
 - (a) a New Zealand commercial ship of 24 metres or more in length; and
 - (b) a New Zealand ship exceeding 24 metres in register length that is to be registered in Part A of the New Zealand Register of Ships by section 6 of the Ship Registration Act 1992.
- (2) A ship of the New Zealand Defence Force that is 24 metres or more in length must—
 - (a) comply fully with the requirements of this Part; or
 - (b) comply only with rules 48.4 to 48.6 inclusive, 48.9 to 48.11 inclusive, and 48.12(4).
- (3) Rule 48.13 applies to a foreign ship of 24 metres or more in length while it is at a New Zealand port or New Zealand offshore terminal.

48.4 Requirement for ship to be measured for tonnage

- (1) The owner of every ship to which rule 48.3(1)(b) applies must ensure that—
 - (a) the ship is measured and the net and gross tonnage of the ship calculated by a surveyor—
 - (i) prior to registration of the ship in accordance with section 15 of the Ship Registration Act 1992; and
 - (ii) after any alteration to the characteristics of the ship in accordance with rule 48.9; and
 - (b) the ship has an International Tonnage Certificate (1969) issued in accordance with rule 48.12.
- (2) The owner of every ship to which rule 48.3(1)(a) or (2) applies must ensure that—
 - (a) the ship is measured, and the net and gross tonnage of the ship calculated, or the gross tonnage only calculated as permitted by rule 48.12(4), by a surveyor—
 - (i) on completion of the initial construction of the ship; and
 - (ii) after any alteration to the characteristics of the ship in accordance with rule 48.9; and
 - (b) the ship has an International Tonnage Certificate (1969) issued in accordance with rule 48.12 or a statement issued by the Director of the gross tonnage only in accordance with rule 48.12(4), as the case may be.

48.5 Determination of tonnage

- (1) Every surveyor measuring a ship and calculating its gross and net tonnage for the purposes of Part 48 shall do so in accordance with rules 48.6, 48.7, and 48.10.
- (2) The owner and the master of a ship to be measured must make the ship and all necessary facilities for the inspection and measurement available to the surveyor.

- (3) The owner and the master must produce for the surveyors use, and retention if required, such plans, drawings, specifications and other documents relating to the ship that the surveyor may require to enable him or her to calculate the gross and net tonnages of the ship.

48.6 Gross tonnage

The gross tonnage (GT) of a ship must be determined by the following formula:

$$GT = K_1V$$

where:

V = Total volume of all enclosed spaces of the ship in cubic metres,

$$K_1 = 0.2 + 0.02 \log_{10}V$$

48.7 Net tonnage

The net tonnage (NT) of a ship must be determined by the following formula:

$$NT = K_2V_c \left(\frac{4d}{3D} \right)^2 + K_3 \left(N_1 + \frac{N_2}{10} \right)$$

in which formula:

(a) the factor $\left(\frac{4d}{3D} \right)^2$ shall not be taken as greater than unity; and

(b) the term $K_2V_c \left(\frac{4d}{3D} \right)^2$ shall not be taken as less than 0.25GT; and

(c) NT must not be taken as less than 0.30 GT, and in which:

V_c = total volume of cargo spaces in cubic metres,

K_2 = $0.2 + 0.02 \log_{10}V_c$

K_3 = $1.25 \frac{GT + 10,000}{10,000}$

D = moulded depth amidships in metres,

d = moulded draught amidships in metres,

N_1 = number of passengers in cabins with not more than 8 berths,

N_2 = number of other passengers,

$N_1 + N_2$ = total number of passengers the ship is permitted to carry as indicated in the ship's passenger certificate; when $N_1 + N_2$ is less than 13, N_1 and N_2 are to be taken as zero,

GT = gross tonnage of the ship as determined by rule 48.6.

48.8 Marking cargo spaces

- (1) Cargo spaces, as defined in rule 48.2, must be permanently marked with the letters "CC" (for "cargo compartment").
- (2) The letters referred to in subrule (1) must be—
- not less than 100 millimetres high; and
 - so positioned that they are readily visible; and
 - confirmed by a surveyor.

48.9 Change of tonnage

The owner of a ship to which this rule applies must ensure that when any characteristics of the ship such as—

- (a) the arrangement; or
- (b) the construction; or
- (c) the capacity; or
- (d) the use of spaces; or
- (e) the total number of passengers the ship is permitted to carry (as indicated in the ship's passenger certificate); or
- (f) the assigned load line; or
- (g) the permitted draught;

are altered resulting in an increase in the ship's tonnage, details of the alterations are forwarded within 14 days of the completion of those alterations to a surveyor to allow the surveyor to re-measure the ship and calculate the new gross and net tonnages.

48.10 Measurement and calculation

Every surveyor calculating the gross and net tonnages of a ship for the purposes of this Part—

- (1) must measure all volumes—
 - (a) to the inner side of the shell or structural boundary plating in ships constructed of metal (irrespective of the fitting of insulation or the like); and
 - (b) to the outer surface of the shell or to the inner side of structural boundary surfaces in ships constructed of any other material; and
- (2) must include in the calculation of total volume the volumes of appendages; and
- (3) may exclude from the total volume the volumes of spaces open to the sea; and
- (4) must take to 2 decimal places all measurements used in the calculation of volumes; and
- (5) must calculate the volumes by mathematical and computational methods acceptable to the Director.

48.11 Oil tankers with segregated ballast tanks

- (1) When measuring a segregated ballast oil tanker as defined in rule 48.2, and to which this rule applies, the surveyor must ensure that the segregated ballast tanks are measured separately and their tonnage is calculated in accordance with rule 48.11(2).
- (2) The surveyor must calculate the tonnage of the segregated ballast tanks referred to in rule 48.11(1) using the following formula:

$$K_1 \times V_b$$

where:

$$K_1 = 0.2 + 0.02 \log_{10} V$$

V = the total volume of all enclosed spaces of the ship in cubic metres as defined in rule 48.2.

V_b = the total volume of segregated ballast tanks in cubic metres measured in accordance with rule 48.10

- (3) On the International Tonnage Certificate (1969) required by rule 48.4, the Director or authorised person must make the following entry for the tonnage of segregated ballast tanks under "Remarks".

"The segregated ballast tanks comply with regulation 13 of Annex 1 of the International Convention for the Prevention of Pollution from Ships, 1973, as modified by the protocol of 1978 relating thereto, and the total tonnage of such tanks exclusively used for the carriage of segregated water ballast is

The reduced gross tonnage which should be used for the calculation of tonnage-based fees is"

48.12 Issue of certificates

- (1) If the owner of a ship to which this rule applies makes an application under section 35 of the Act for an International Tonnage Certificate (1969) in respect of the ship, and the Director or authorised person to whom application is made is satisfied that a surveyor has measured the ship and calculated the gross and net tonnages in accordance with the requirements of this Part, the Director or authorised person to whom application is made must issue, under section 41 of the Act, an International Tonnage Certificate (1969) in respect of the ship, in the form as shown in Annex II of the Tonnage Convention.
- (2) Subject to 48.12(3)(b), when there is a decrease in the net tonnage of a ship to which this rule applies due to—
 - (a) an alteration in the characteristics of the ship; or
 - (b) an alteration to the load line because of a change in trade;a new International Tonnage Certificate (1969) must not be issued by the Director or authorised person to the ship until twelve months after the date of issue of the ship's current International Tonnage Certificate (1969).
- (3) The Director or authorised person may issue a new International Tonnage Certificate (1969) to a ship to which rule 48.12(2) applies within 12 months of the date of issue of the current International Tonnage Certificate (1969) if—
 - (a) the ship is transferred to the New Zealand flag; or
 - (b) the ship undergoes alterations or modifications considered by the Director or authorised person to be major changes.
- (4) A New Zealand Defence Force Ship may be issued with—
 - (a) an International Tonnage Certificate (1969) in accordance with rule 48.12(1); or
 - (b) a statement, issued by the Director, of the gross tonnage only, that has been calculated in accordance with this Part¹.

48.13 Port State Control

- (1) Subject to rule 48.13(2), the Director may inspect a ship flying the flag of a state party to the Tonnage convention when at a New Zealand port or New Zealand offshore terminal to verify—
 - (a) that the ship has a valid International Tonnage Certificate (1969); and
 - (b) the main characteristics of the ship correspond to the data given in the certificate.
- (2) In no case must the inspection authorised by rule 48.13(1) cause any delay to the ship. If the inspection reveals that the main characteristics of the ship differ from those on the International Tonnage Certificate (1969) so as to lead to an increase in the gross

¹ Since warships do not carry cargo or passengers a net tonnage cannot be determined for such ships in accordance with rule 48.7. Therefore a statement indicating the gross tonnage only of such ships is to be issued by the Director in lieu of an International Tonnage Certificate (1969).

tonnage or the net tonnage, the Director must inform the Government of the state whose flag the ship is flying without delay.

Appendix 1 Figures referred to in the definition of "excluded spaces" in section 1

In the following Figures: O = excluded space

C = enclosed space

I = space to be considered as enclosed space

Hatched in parts are to be included as enclosed spaces.

B = breadth of the deck in way of the opening.

In ships with rounded gunwales the breadth is measured as indicated in Figure 11.

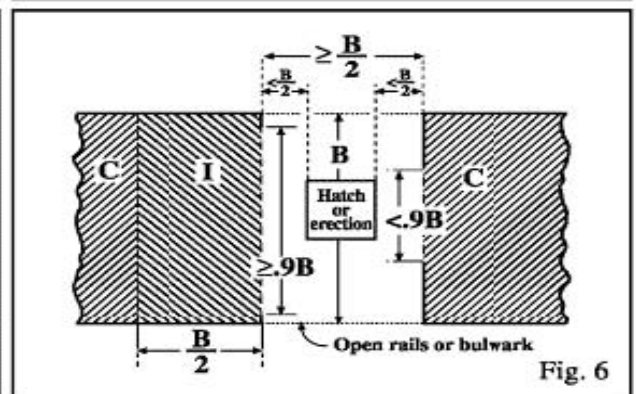
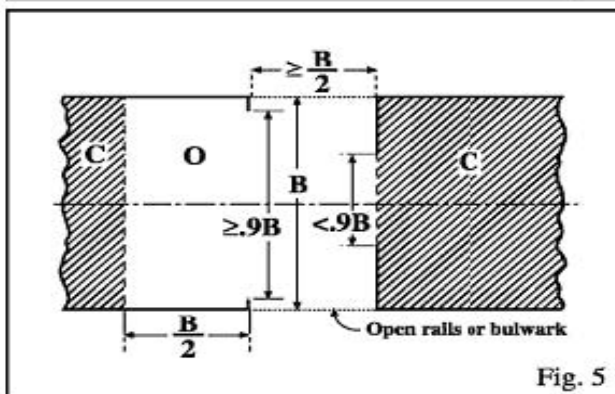
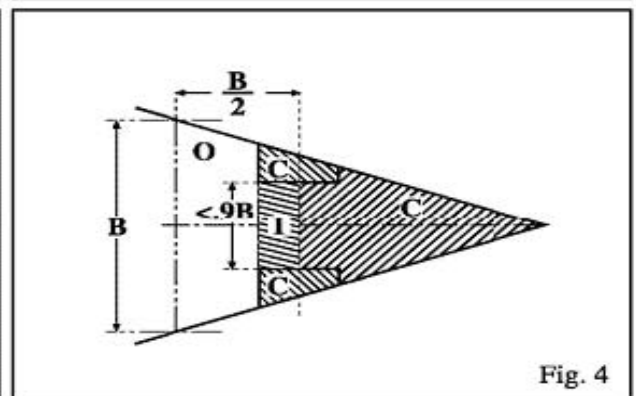
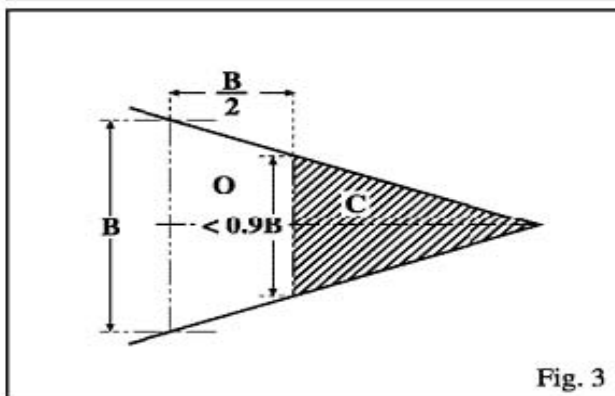
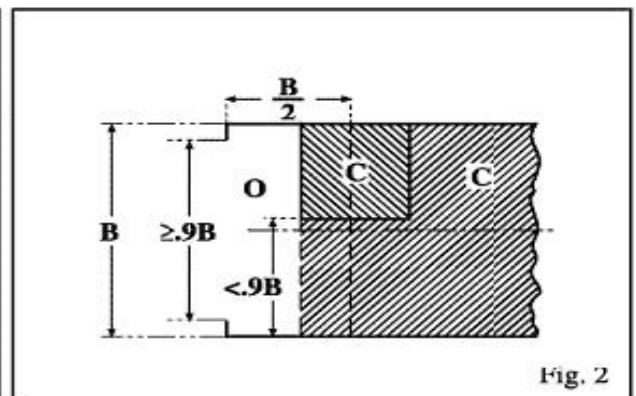
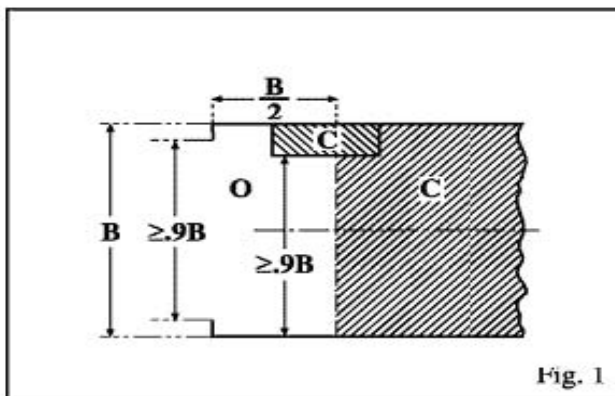

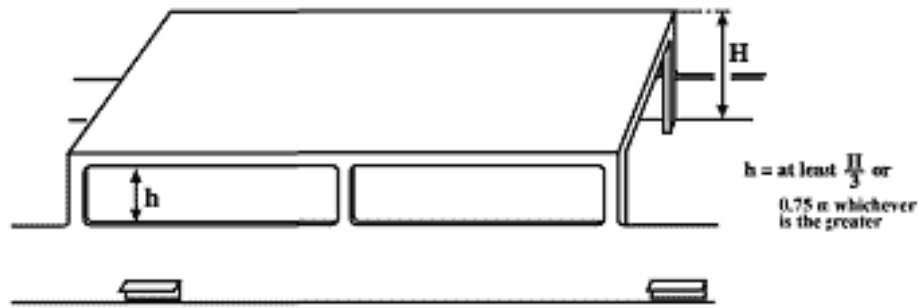

Fig. 7

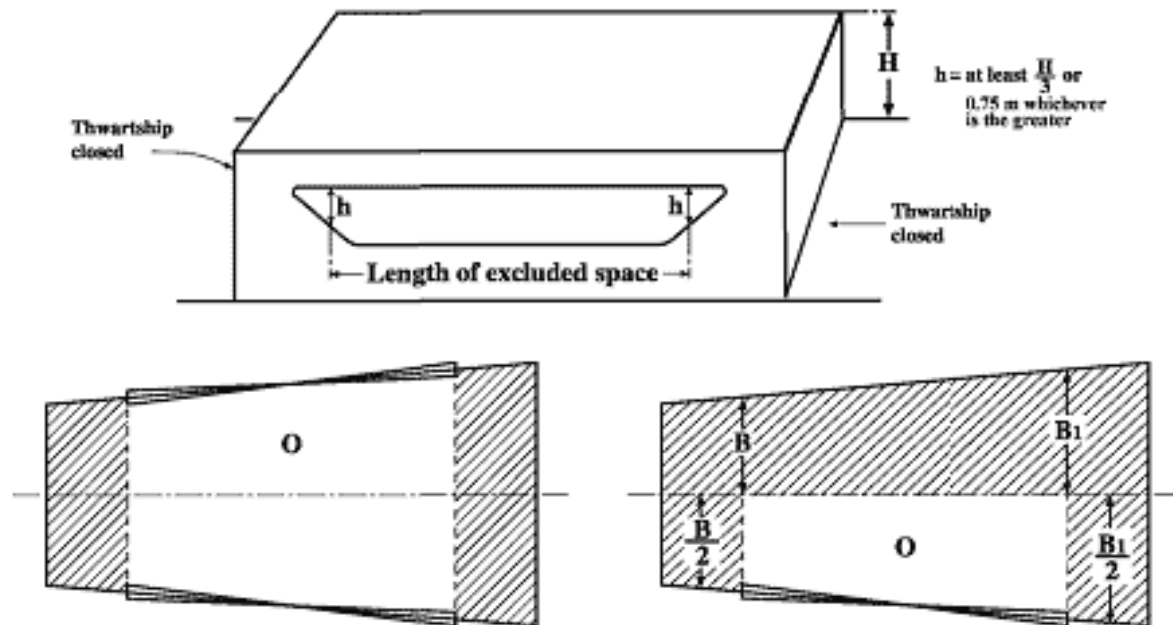

Fig. 8

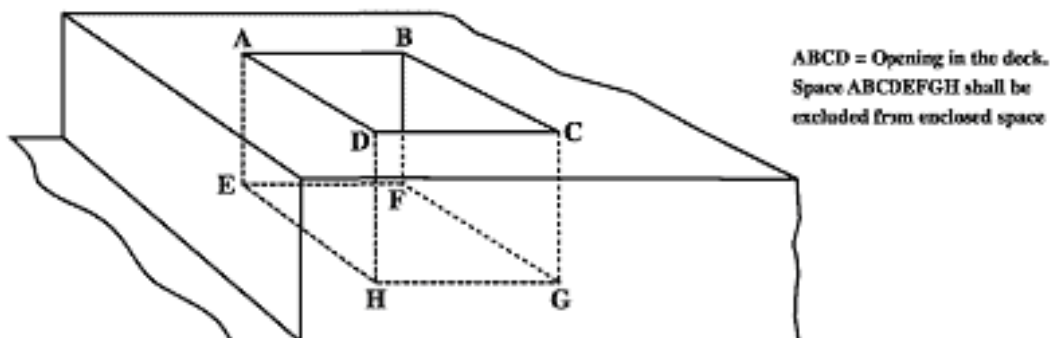

Fig. 9

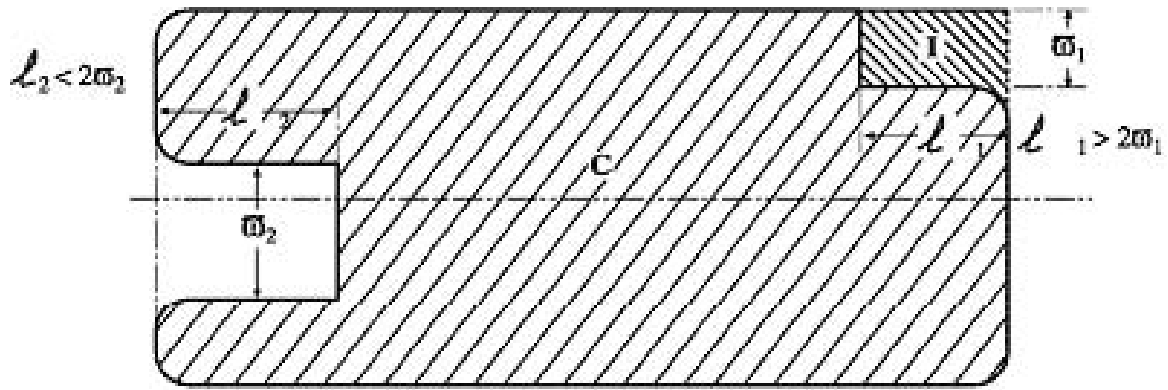

Fig. 10

Ships with Rounded Gunwales

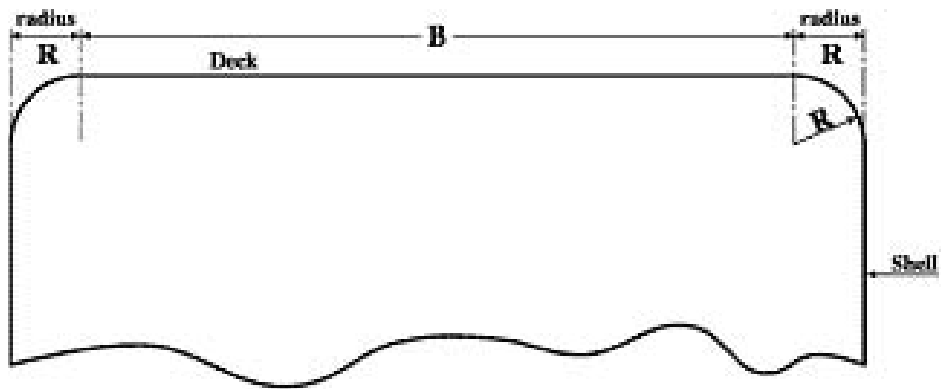

Fig. 11